

# STEMSEL Intermediate Project 3: Human Conductor

( Requires 2 extra wires in addition to kit )

## Problem

We want to design a circuit that will turn on a fan and a light, but only when there is at least one person to help complete the circuit. You will actually be a part of this circuit!

## Background

You may have seen electrical transmission wires on poles, but have you ever wondered what they are exactly, and how the electricity goes from the power station to your house? Well, it's quite simple, the transmission wires are what we call a conductor, so they are like a highway for electricity, and by using transformers (not Optimus prime though), engineers adjust the voltage in the transmission wires to avoid transmission loss and provide a constant and stable voltage to you and millions of customers. But what is a "conductor", and what is "voltage"? Good question, now I shall briefly explain them. First, you may have already learned about atoms, which are tiny particles that make up everything around us. More specifically you may have learned about the electrons that orbit around the atom. In some types of materials, it is possible to give these electrons a push and they can jump from one atom to the next. We call this movement of electrons an "electric current", or more commonly electricity, and the push that causes the electrons to move is called "voltage".

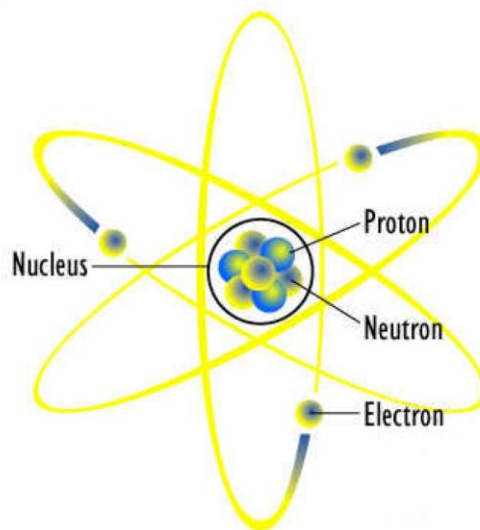

Figure 1: an atom

Ok, now if you would like to wake up, here's a simpler explanation. Consider a hose and water; if you turn on the tap the water flows along the hose and out of the end. The water comes out because of the pressure that pushes it along, and the water is able to flow through the hose because it is hollow. The same thing happens with electricity; the electrons move because they are pushed along by the voltage, and the electrons can move easily between the atoms in the conductor (i.e. it's hollow for electrons). It's quite interesting that a human's body is also a good conductor, so watch out for naked wires and never touch electrical sockets with your hand, and listen to your parents and teachers.

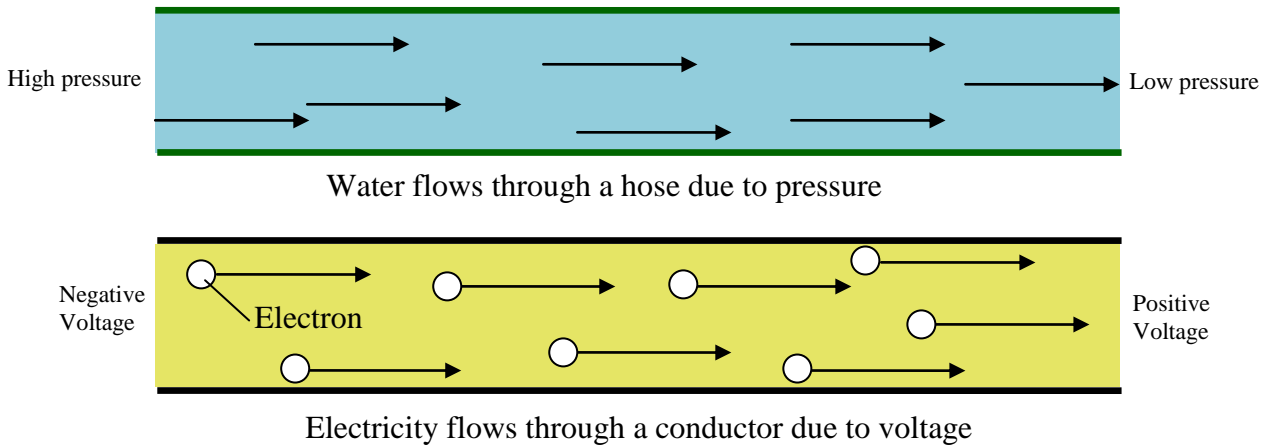
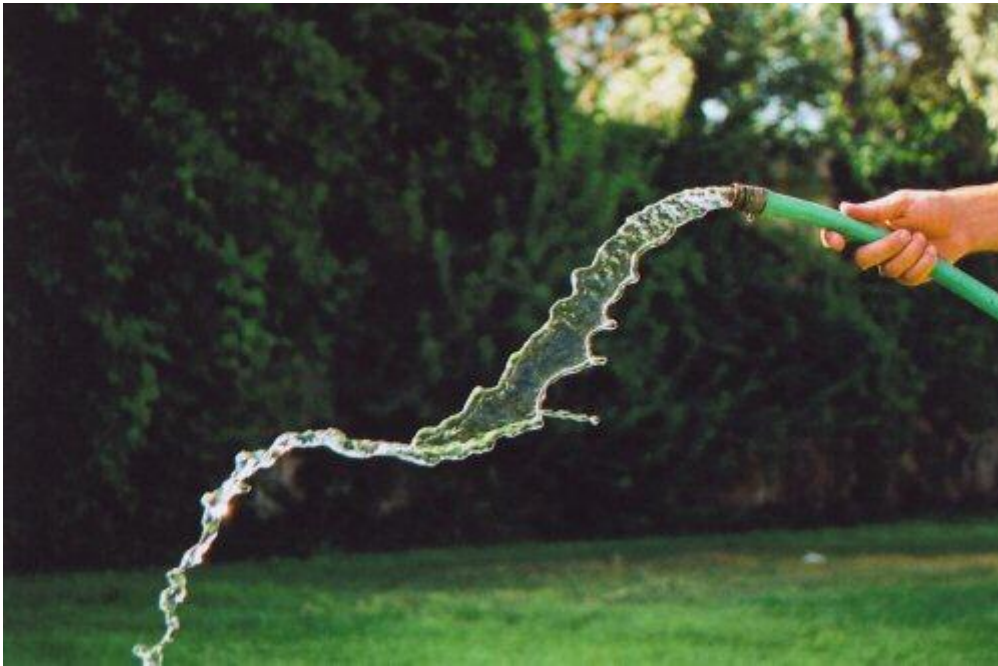

Figure 2: Comparison between flowing water and electricity

Materials such as wood and plastic that do not conduct electricity are called insulators. Can you think of other things that are conductors or insulators?

Now you have some idea about the fundamentals of electricity transmission and voltage, it's time think about how we use electricity. Watching TV, using a computer, lighting and countless other applications all use electricity. What you may not know is that many of these devices use microchips to control how the electricity flows.

Microchips are very similar to a brain. For example, if you were walking and suddenly saw a huge T-rex coming at you, you would run away (well you shouldn't because tyrannosaurus are more sensitive to moving objects). In this case your eyes are the inputs that tell your brain that there is a T-rex, then your brain must decide what to do and activate an output, in this case your legs to start running. Microchips also use inputs like light sensors or buttons to find out about their environment, work out what needs to be done and turn on outputs like a buzzer or a light. Fortunately we don't need to worry about T-rex for now, let's focus on conductors and voltage.

In this project, we are going to assemble and program a STEMSEL controller board to detect the voltage passed across your body. The principle is that the circuit generates a voltage at the transmitter pin, and if there is a conductor between the transmitter pin and the receiver pin (where it receives current), a light bulb and a fan will turn on.

### Ideas

Our fingers won't fit in the screw terminals, so how can we become a part of the circuit? Could we touch another conductor (wires)? If the electricity has to flow out of the STEMSEL controller board, through us and back to the STEMSEL controller board how should we set up our wires? Will the wires be inputs or outputs? How can the microchip tell if there is electricity flowing into the receiver wire? Will the voltage change?

### Plan

We will need to measure and compare a voltage difference between two terminals than activate some outputs if the electricity is flowing. We will need two pieces of wire that people can hold as the voltage receiver and voltage transmitter, as well as a light bulb and a fan for our outputs. Last but not least, we need a STEMSEL controller board.

The transmitter wire will be where the electricity leaves the STEMSEL controller board and will be an output (the electricity is flowing out of the board). The receiver is where the electricity flows back into the STEMSEL controller board, so it will be an input.

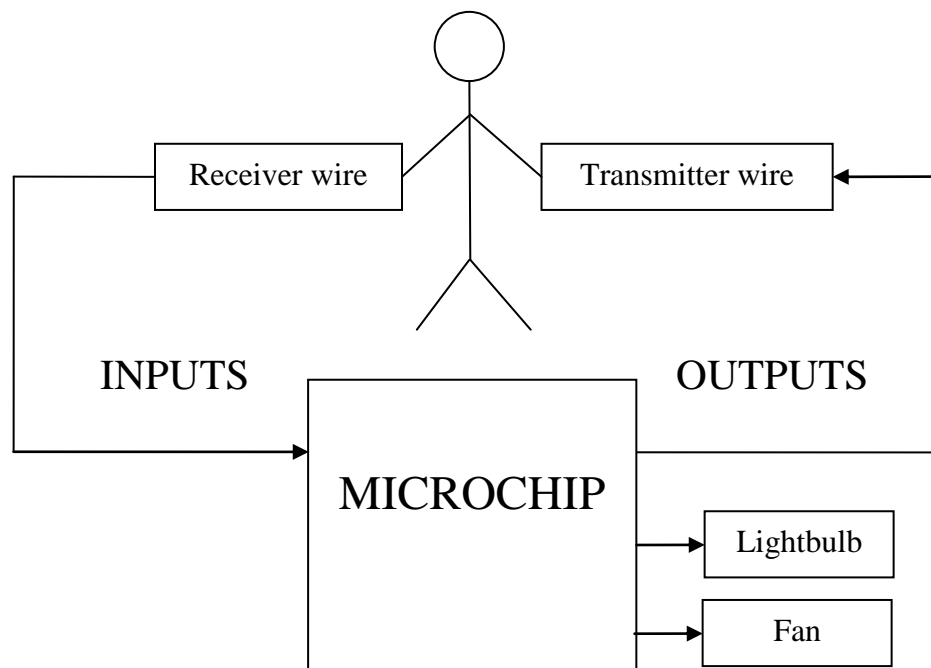

Figure 3: circuit plan

When the circuit is completed by a person holding the wires, the voltage on the receiver pin will increase. We will need to set a threshold value, and when the voltage on the receiver wire is above this threshold the microchip will know that the circuit is complete and to turn on the fan and lightbulb.

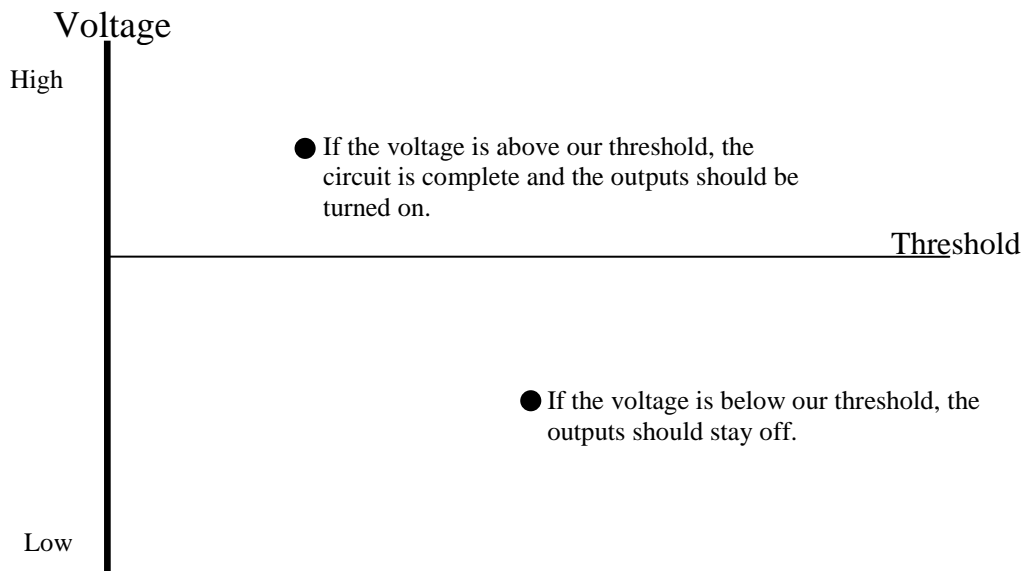

Figure 4: threshold graph

## Design

Use the driver button to add the fan and lightbulb to the circuit design. Since there is no special icon for the transmitter and receiver wires, these will need to be added in a different way. For the receiver click the Input button, than select **Analog Input** from the circuit list. For the transmitter click the Outputs button and select **PWM output** from the circuit list.

Design the layout of your STEMSEL controller board so it looks like this:

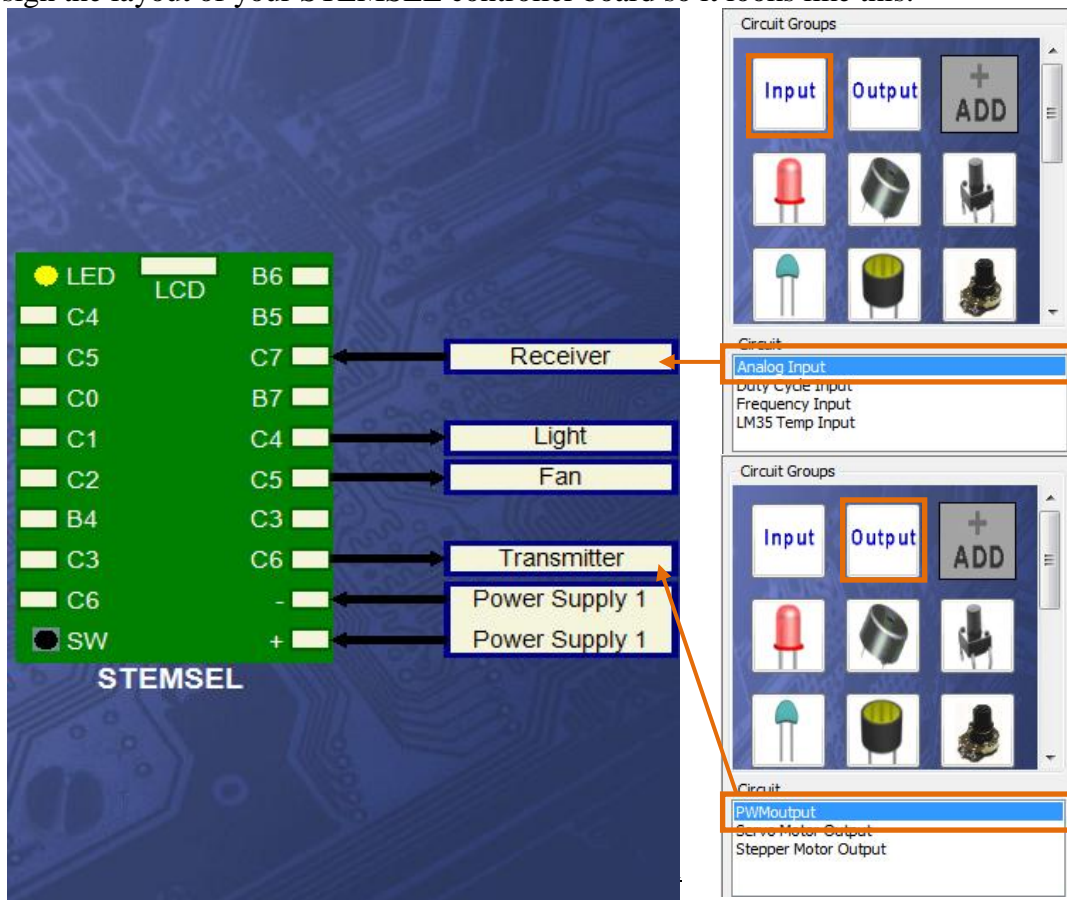

Figure 5: circuit design

## Build the circuit

When you are finished the design, it's time to assemble the circuit using your kit. Put the black wire from the lightbulb into the negative terminal and the white wire into C4. For the fan put one wire into C5 and the other into the negative terminal. The receiver and transmitter wires can just be put into pins C7 and C6 respectively.

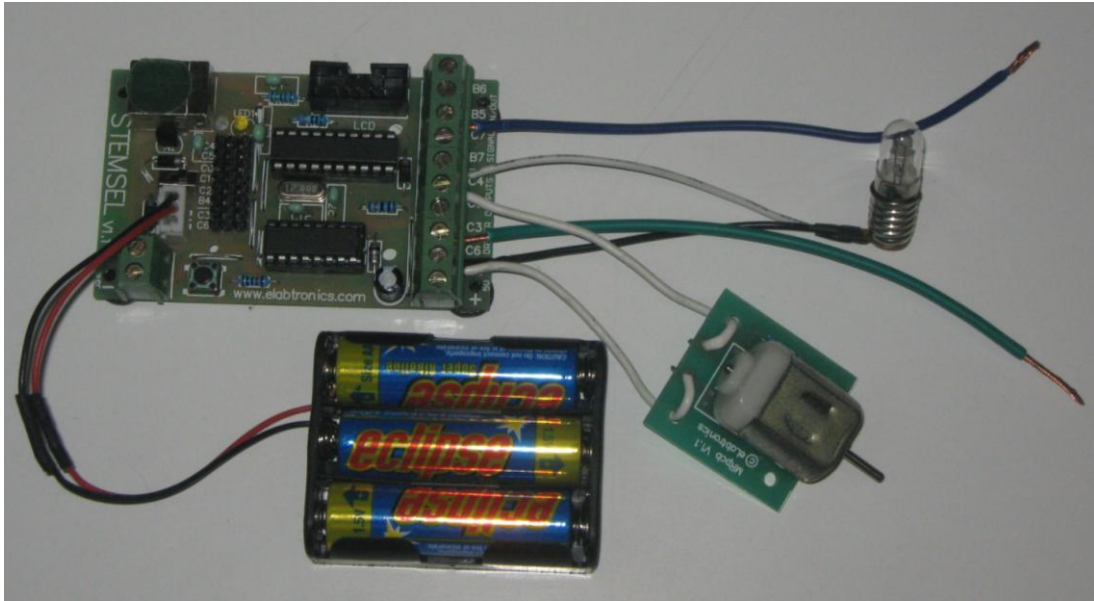

Figure 6: circuit

## Programming

Once you have assembled the circuit, send the design to Corechart by clicking the “Send to Corechart” button, then click the “Send Program To Chip” button to program the microchip with the test routines. After you have verified that the lightbulb and fan are working, delete the test routines so we can write our own program.

Just like we said in the plan, we want our program to set a threshold voltage which can be compared to the current voltage. If the current voltage is greater than the threshold, we will turn on the light bulb and the fan, if it is smaller than the threshold the circuit will do nothing.

Here are some steps for reference:

1. Turn on the transmitter using an OnOffPin icon.
2. Click the “**Inputs**” button, and select “**Analog\_In**” in “Icon properties” window. Double click it and store data from “**Receiver**” as “**Volts**”.
3. Use a Compare icon to compare “**Volts**” with a threshold value of 4V and tick the above checkbox. If the voltage on Receiver is higher than 4V, activate the light bulb and the fan such that they flash on and off once per second (i.e. 50 hundredths on and 50 hundredths off).
4. Add a “**GOTO START**” before “**End Main**”.

Now your program should look like this:

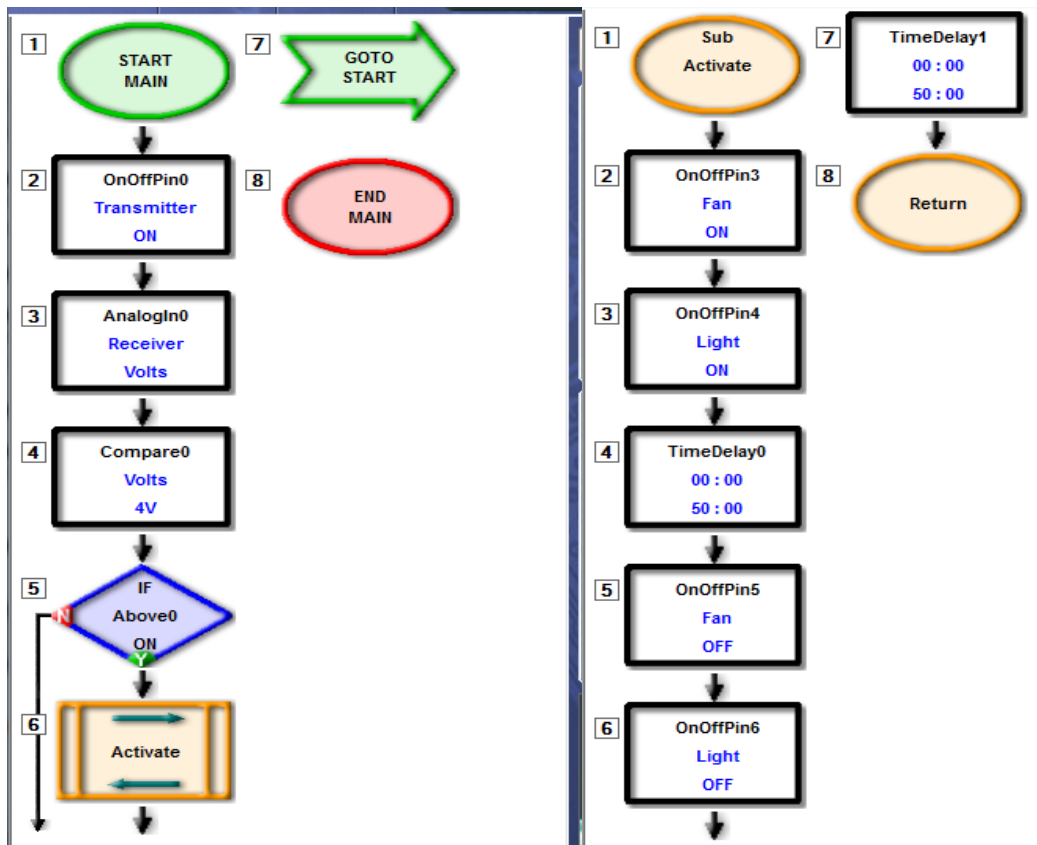

Figure 7: Human conductor program

After you send the program to the microchip, touch the receiver wire and the transmitter wire together, and the light and fan should turn on. What if you use your left hand to touch one wire and your right hand to touch the other? You actually become a part of the circuit as the electricity is able to flow out of the transmitter through you and back into the receiver. This circuit only uses 4.5 volts so it is safe to use it like this. However voltages above 50V can kill people. The power points in your house use 240V, so it is necessary to be careful when you use them.

### Activity

You found that the electricity can pass through you, but can it pass through even more people? Try holding hands with the person next to you, then touch one of the wires each and see if you can still get the light and fan to turn on. Try it with more people, and find out the maximum number of people you can have!

### Summary

Voltage is a push that can cause electrons to flow from one atom to another, resulting in electricity. If the electrons can flow easily through a material we call it a conductor. By using a microchip and couple of wires, we can detect the voltage passed through a conductor (again, use electricity safely). During this project, we learned how we can use the microchip to compare two values. It may look simple, however it is nearly impossible without microchips. The little black box in front of you is one of the biggest milestones of our civilization. Do you want to invent or improve something like microchips that make human beings revive T-rex, or set sail into deep space? Study engineering.